

## Layout drawing: TYPE IDR/MDR

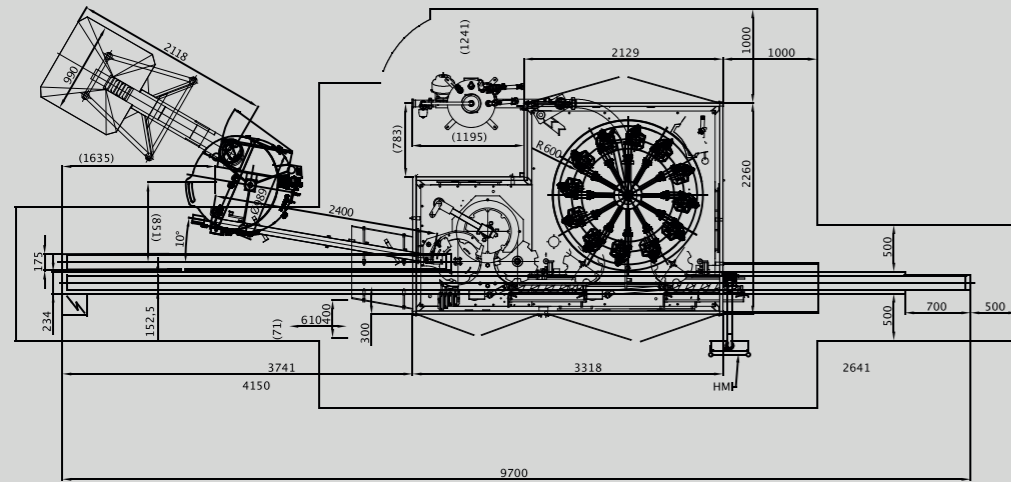

ALL INFO  
HERE ON THE  
INSIDE PAGES



### Containers and closures? It doesn't matter, we can do all of them!

Bottle unscramblers, filling machines and capping machines. Together with the necessary conveyor technology we can do complete packaging lines for your production.

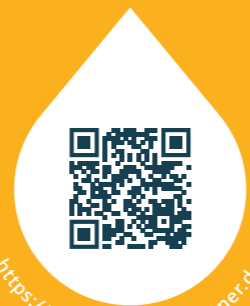

## BREITNER Monoblock rotary filling & closing machine

For high output with large batch sizes. Continuous operation and large dosing range with flow measurement, max. 30 filling stations and max. 12 capping stations for maximum output. Configurable with many options for different products and their properties.

BREITNER Abfüllanlagen GmbH  
Friedrich-Groß-Straße 5  
74523 Schwäbisch Hall

+49 791 95035-0  
info@breitner-abfuellanlagen.de  
www.breitner-abfuellanlagen.de



English

Cosmetics  
Chemistry  
Food  
Pharmacy

# BREITNER Monoblock machine

 350/min



Under-level filling



Inductive flow measurement



Mass flow measurement



Ex-protection



Bottles



Canisters



CIP/SIP



Torque adjustable



Screw cap



Trigger pumps



## Technical data

Output capacity: up to 350/min

Container diameter/width: up to 140 mm

Container height: up to 350 mm

Filling stations: 16 to 30 filling stations

Closing stations: 4 to 12



<https://idrmrvideos.breitner.de>

## Fact sheet

- ▶ Container sizes: 20 ml bottles to 5 l canisters
- ▶ High output rates
- ▶ Continuous and consistent production
- ▶ Precise filling & capping technology on a compact machine frame

**BREITNER**<sup>®</sup>  
ABFÜLLANLAGEN GMBH