

Layout drawing: TYPE BFA

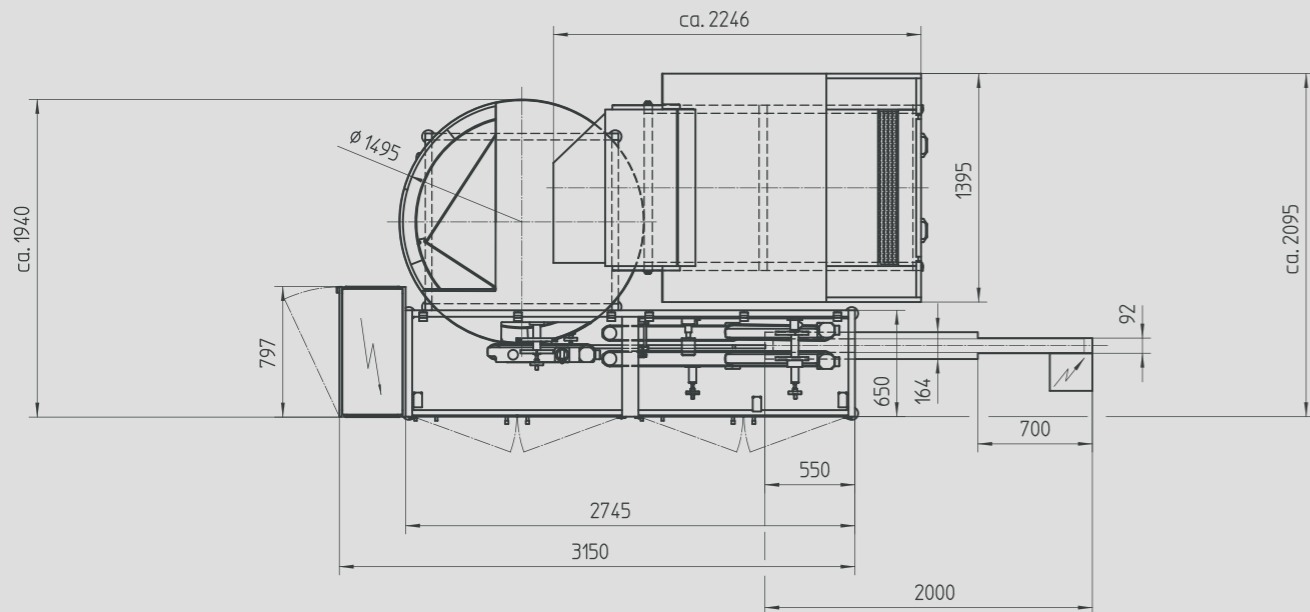

ALL INFO
HERE ON THE
INSIDE PAGES



Containers and closures? It doesn't matter, we can do all of them!

Bottle unscramblers, filling machines and capping machines. Together with the necessary conveyor technology we can do complete packaging lines for your production.



BREITNER Standard bottle unscrambler

The cost-effective solution for simple bottle formats (symmetrical, straight-walled) and medium output up to 150 bottles/min.

BREITNER Abfüllanlagen GmbH
Friedrich-Groß-Straße 5
74523 Schwäbisch Hall

+49 791 95035-0
info@breitner-abfuellanlagen.de
www.breitner-abfuellanlagen.de



English

Cosmetics
Chemistry
Food
Pharmacy

BREITNER Standard bottle unscrambler

 150/min



Hopper size
variable

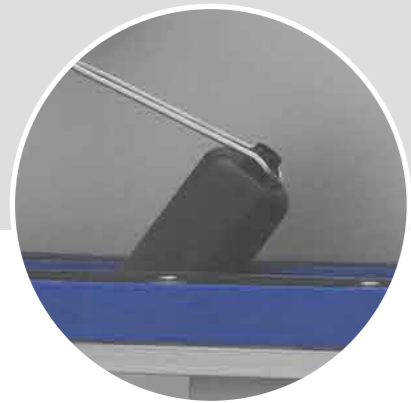

Technical data

Output capacity:	up to 150 bottles/min
Container diameter/width:	up to 80 mm
Container height:	up to 320 mm
Hopper volume:	1 to 3 cbm



Fact sheet

- ▶ Few format parts, quick and easy changeover
- ▶ Little space required in the hall
- ▶ Simple, controllable technology
- ▶ High-quality, stable design
- ▶ All adjustment positions with scale or counter

BREITNER[®]
ABFÜLLANLAGEN GMBH