

**Layout drawing:
TYPE IDL/MDL for bottles**

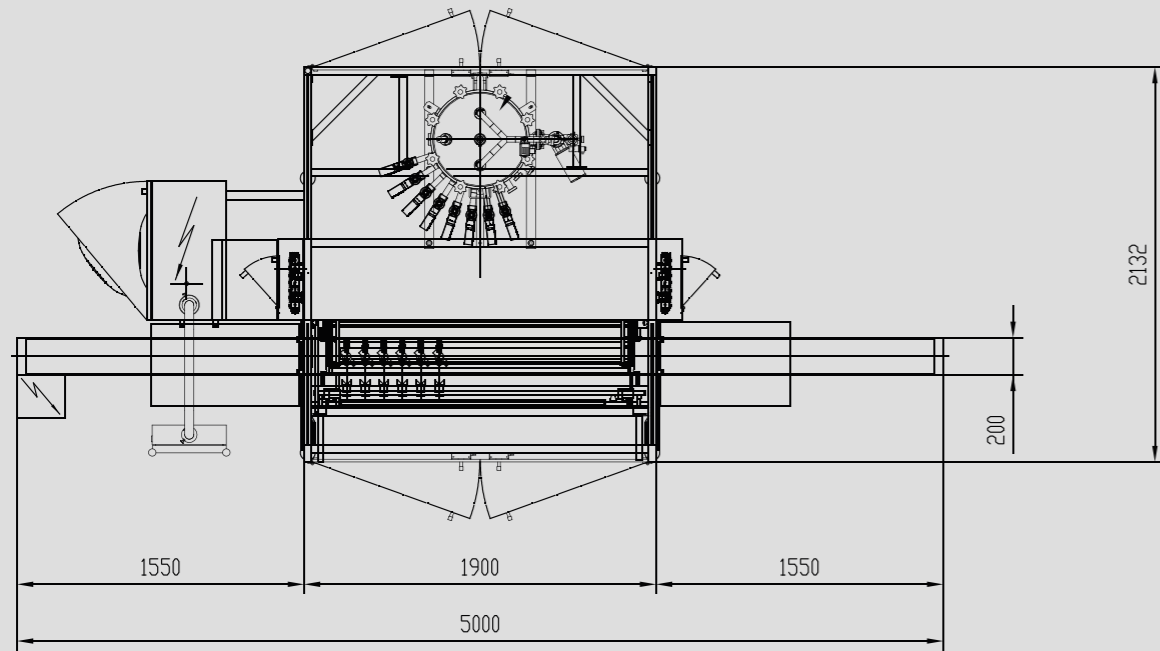

ALL INFO
HERE ON THE
INSIDE PAGES

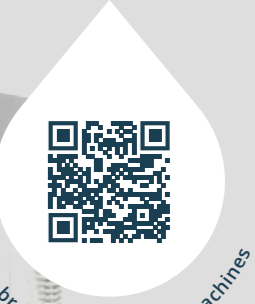

**Containers and closures?
It doesn't matter, we can do all of them!**

Bottle unscramblers, filling machines and capping machines. Together with the necessary conveyor technology we can do complete packaging lines for your production.



**BREITNER
Linear filling machine
for bottles**

Best-selling model, highly variable in use. Large dosing range with flow measurement for small bottles to large canisters, up to max. 16 filling stations and 2600 mm width. Configurable with many options for different products and their properties.

BREITNER Abfüllanlagen GmbH
Friedrich-Groß-Straße 5
74523 Schwäbisch Hall

+49 791 95035-0
info@breitner-abfuellanlagen.de
www.breitner-abfuellanlagen.de



English

Cosmetics
Chemistry
Food
Pharmacy

BREITNER

Linear filling machine for bottles

 150/min



Linear working



Under-level filling



Inductive flow measurement



Mass flow measurement



Ex-protection



Bottles



CIP/SIP



Cross over



Technical data

Filling stations: 2 to 16 filling stations

Container sizes: 20 ml up to 5 liters

Container diameter/width: up to 270 mm

Container height: up to 400 mm

Output capacity: up to 150 bottles/min

Frame sizes: 1500/1900/2600



<https://idmdl.breitner.de>

Fact sheet

- ▶ Large dosing range
- ▶ Under and over level filling (depending on product) with servo drive
- ▶ Practically no format parts, quick and easy changeover
- ▶ Selectable product container size
- ▶ Filling pipes are customized to the container
- ▶ Product container with mixer
- ▶ Heated product container

BREITNER[®]
ABFÜLLANLAGEN GMBH



TYPE IDL/MDL

